

Studio System™

BMD Design Guide

- 1 Introduction to Bound Metal Deposition™
- 2 Summary of BMD™ Guidelines
 - A Design guidelines (CAD modeling)
 - B Live Studio™ model prep guidelines
- 3 Selecting Parts for 3D Printing
- 4 BMD™ Considerations and Best Practices
 - A Printing with infill
 - B Design optimization for printing, debinding, and sintering
- 5 Glossary



Bound Metal Deposition

The Studio System™ automates metal 3D printing. Integrated through LiveStudio™, Desktop Metal's cloud-based software, it delivers a seamless workflow for printing complex parts in-house—from digital file to sintered part.

Materials

There are two types of material available for the Studio System™ platform:

- **v.2 materials: print → sinter**

Now available for use with Studio System™ 2, these materials follow a streamlined two-step process, thanks to an updated binder composition, and go directly from the printer into the furnace.

- **v.1 materials: print → debind → sinter**

These materials have an intermediate solvent debinding step in the debinder.

Print

The Studio System™ printer uses a process called Bound Metal Deposition™, or BMD™. BMD™ is similar to one of the most widely-used 3D printing technologies, Fused Filament Fabrication, FFF. Instead of filament, the Studio System™ uses bound metal rods—metal powder held together by a wax and polymer binder. The rods are fed through a heated extruder onto the build plate. The printer shapes the part layer by layer, line by line — producing a printed or “green” part.

Debind (v.1 materials only)

The green part is then placed into the debinder where it is immersed in proprietary debind fluid, dissolving primary binder and creating an open-pore channel structure to prepare the part for sintering. Once the debind cycle is complete the part is referred to as a “brown” part.

Sinter

The green part (v.2 materials) or brown part (v.1 materials) is placed into the furnace where it is heated to temperatures near melting—removing any remaining binder and causing the metal particles to fuse together as the part is sintered. This step necessitates design considerations unique to BMD™ because sintering has implications for part features, build orientation, and support structures.

Summary of BMD™ Guidelines

To leverage the advantages of additive manufacturing, it is important to optimize your design for the BMD™ process—printing, debinding (if necessary), and sintering.

CAD Modeling Guidelines

Dimensions shown are for the designed model / final part unless otherwise stated.

Standard Printhead

Hi-Res Printhead

400 µm

250 µm

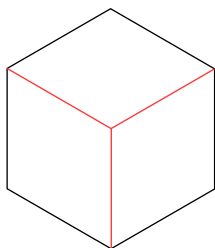

Maximum Part Size

X **240mm** 9.4in
Y **150mm** 6.0in
Z **155mm** 6.1in

X **80mm** 2.4in
Y **80mm** 2.4in
Z **80mm** 2.4in

The build volume of the Studio printer is 300 x 200 x 200 mm (12 x 8 x 8 in). Due to part shrinkage during sintering, the bounding box is 240 x 150 x 155 mm (9.4 x 6.0 x 6.0 in). Live Studio™ scales parts using a scaling factor between 17% and 25%, depending on material. To optimize for fabrication success, **the recommended maximum part size is 150 x 150 x 110 mm (6.0 x 6.0 x 4.3 in) with standard printhead.**



Minimum Part Size

X **6mm** 0.24in
Y **6mm** 0.24in
Z **6mm** 0.24in

X **3mm** 0.14in
Y **3mm** 0.14in
Z **3mm** 0.14in

The minimum part size considers the minimum number of bottom layers, top layers, and toolpaths within a wall required to produce a successful part.

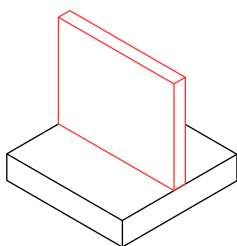

Minimum Wall Thickness

0.8-1.0mm
0.03-0.04in

0.6mm
0.02in

The minimum wall thickness considers structural integrity during sintering. Wall thickness must be **at least two toolpaths wide**, or approximately 0.8-1mm depending on material. When printing a wall greater than 8mm tall, the ratio of height to width must not exceed 8:1 (Except Copper material that is 6:1)

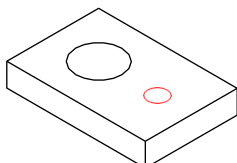

Minimum Hole Size

1.50mm
0.06in

0.75mm
0.03in

Similar to most FFF style printers, holes on the Studio System print slightly undersized. To ensure accurate hole size, hole dimensions should be increased by 0.30 – 0.35mm depending on the print orientation. Alternatively, hole dimensions can be left as-is and machined to the intended specification.

Summary of BMD Guidelines

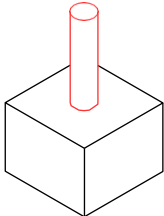
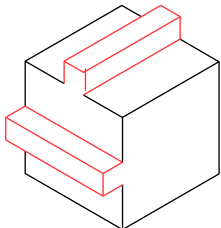
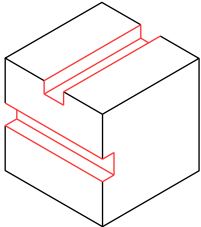
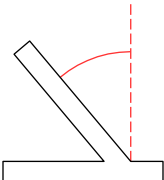
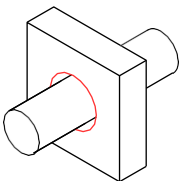
CAD Modeling Guidelines	Standard Printhead		Hi-Res Printhead	
	400 μm		250 μm	
	Minimum Pin Diameter	3.0mm 0.12in	1.5mm 0.06in	
	Pins should obey the aspect ratio guideline of 8:1 for all materials except copper (aspect ratio 6:1).			
	Minimum Embossed Feature	X/Y W 0.45mm 0.018in H 0.50mm 0.020in Z W 0.25mm 0.010in H 0.50mm 0.020in	W 0.30mm 0.012in H 0.30mm 0.012in W 0.15mm 0.006in H 0.30mm 0.012in	
	Embossed features are proud of the surface of the model. If an embossed feature is too thin, it likely will not print.			
	Minimum Debossed Feature	X/Y W 0.45mm 0.018in H 0.50mm 0.020in Z W 0.25mm 0.010in H 0.50mm 0.020in	W 0.30mm 0.012in H 0.30mm 0.012in W 0.15mm 0.006in H 0.30mm 0.012in	
	Debossed features are typically used for surface detailing and text on the surface of the model. If a debossed feature is too thin, it risks over-extrusions that fill in the engraved feature.			
	Minimum Unsupported Overhang Angle	40°	40°	
	Overhangs greater than 40° from vertical axis require supports. Supports are important during printing, but are most critical during sintering. While the printing process can tolerate a 40° overhang, sintering may tolerate much less. It depends on the geometry, but avoid cantilevered masses and small features that cause the entire part to sit on top of supports.			
	Minimum Clearance	0.3mm 0.012in	0.2mm 0.0080in	
	The additive nature of 3D printing enables the fabrication of multiple parts as printed in-place assemblies with moving or embedded parts. Interlocking components should have 0.3mm (0.012in) of clearance.			

Summary of BMD Guidelines

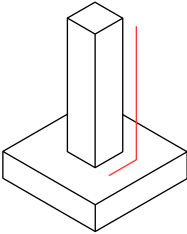
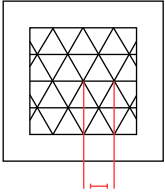
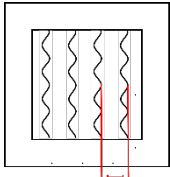
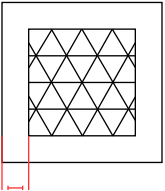
Modeling Your Part In CAD		Standard Printhead 400 μm	Hi-Res Printhead 250 μm
	Aspect Ratio	8:1 (all materials) 6:1 (copper)	8:1 (all materials) 6:1 (copper)
<p>Unsupported tall, thin features are challenging for debind and sintering processes and should be limited when possible.</p>			
<p>The ratio of height to width for tall walls or pillars should not exceed 8:1 except for copper with an aspect ratio of 6:1. Tall cylinders and walls are the least stable geometries.</p>			
Live Studio™ Guidelines			
	Infill Wall Spacing v.1 materials	1.50-3.20mm 0.06-0.13in	1.75mm 0.07in
<p>In Live Studio™, the default setting for infill line spacing is 2.8 mm for the standard print head and 1.75mm for the high-res printhead. Increasing the spacing between lines of infill makes the part less dense while decreasing the spacing between infill lines makes the part more dense. Modifying this setting will impact the duration of the debind cycle.</p>			
	Infill Wall Spacing v.2 materials	3mm 0.12in	1.3mm 0.05in
<p>For v.2 materials, the infill is printed as a TMPS structure. This structure has a coverage area of ~30%. This means that the interior of parts is ~30% metal and ~70% void space. Infill printing in metal parts allows for the printing of lightweight parts with high strength.</p>			
	Maximum Shell Thickness	4mm 0.16in With infill 10mm 0.40in Without infill (v.1 materials)	5.25mm 0.20in Without infill (v.2 materials)
<p>Together, the part's walls, top layers, and bottom layers comprise the part shell. The limit to shell thickness is due to the debind process, if applicable. Debind duration is a function of overall cross-sectional thickness. Parts with thick walls or a high-density infill will take longer to debind. According to the part geometry, higher is binder mass from larger shell thickness, lower is the control of binder removal and may occur non optimum results after thermal debinding and sintering step.</p>			

Live Studio™ Guidelines



Maximum part mass (green)

1.2-1.5 Kg

1.2-1.5 Kg

To optimize fabrication success, the green part total mass recommendation is between **1.2 and 1.5 Kg**. Above this value, higher mass leads to less behavior control in sintering and higher risks in terms of result and cost.

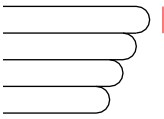

Layer Height

150 μm -200 μm 50 μm

Larger layer heights allow for faster print times, but there is a trade-off between print time and surface quality. Smaller parts are better suited to a finer layer height to ensure that fine features are within tolerance. Larger parts use the Standard+ profile to ensure fast print times and strong support structures.

Selecting parts for BMD™

Selecting Parts for BMD

Evaluate parts across applications. Begin by selecting custom parts, low-volume parts, complex parts, and parts with long lead times. Use the decision funnel to eliminate parts based on the following characteristics.

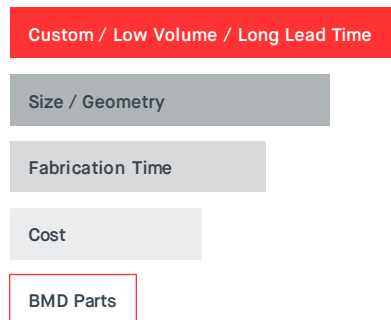

Additive manufacturing and the Studio System™ open up new capabilities for producing metal parts. However, not all parts make sense to 3D print and oftentimes simple geometries or parts produced in high volumes are more cost-effective to produce with other technologies. Part geometry, economics, and performance are important factors tied to the fabrication method.

As you evaluate parts for BMD™, review a wide range of parts—keep in mind your objective and use the decision funnel (left) to down-select parts best suited for the process. To begin, identify **custom** parts, **low-volume** parts, **complex** parts, and parts with **long lead times**. Eliminate parts not appropriate based on **size** and/or **geometry** and that cannot be modified to follow the BMD™ design guidelines. Use estimates for BMD™ **fabrication time** and part **cost** to eliminate parts for which BMD™ is not cost-competitive or does not reduce fabrication time. Benchmark the selected parts to evaluate part **performance**.

When selecting parts for BMD™, it is important to remember existing parts were likely designed for another fabrication process. There may be value in producing these parts on the Studio System™ without design modifications - in fact, this is what most people do when they start using the System. However, simply replicating a design subjects the part to the restrictions of the 3D printing process whereas adapting or optimizing your design for BMD™ allows you to capture the benefits of 3D printing.

Estimating Part Cost

Build media, debind fluid (v.1 materials), furnace gas, and electricity are the largest drivers of part cost.

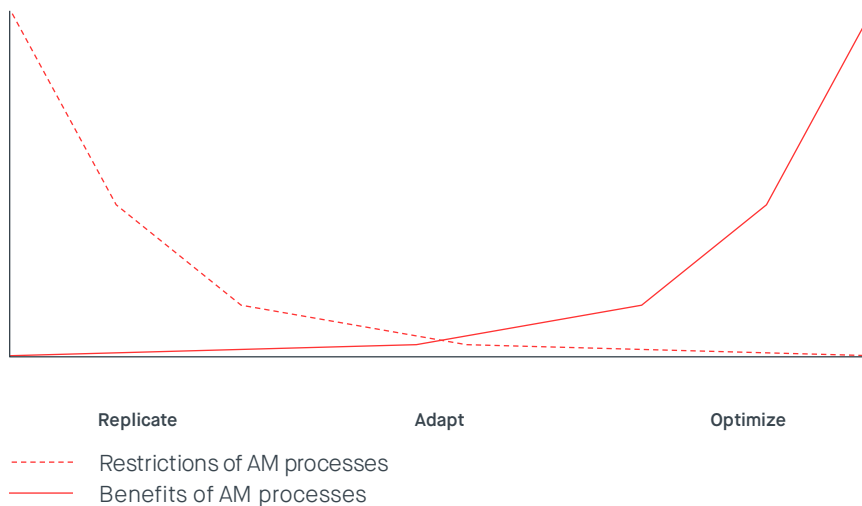
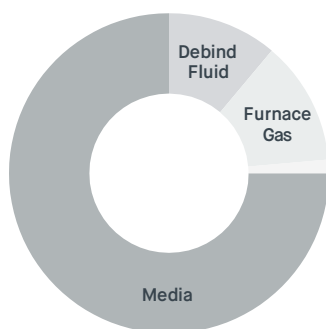

Cost estimates are essential for selecting parts for fabrication on the Studio System™. Upload your design file to Live Studio™ to view estimates for media costs (metal and ceramic), as well as estimated print, debind (if applicable), and sintering times. Depending on the way your organization calculates ROI, other costs like equipment, energy, service, and consumables, may be important to take into account.

Considerations & Best Practices

Printing with Infill

The Role of Infill

Similar to parts printed using Fused Filament Fabrication (FFF), all parts printed with the Studio System™ contain infill. Infill describes the internal lattice structure printed throughout the part, enclosed by the solid walls that make up the shell of the part—creating what is called, *closed-cell infill*.

The ability to lightweight parts with infill is a key advantage with Additive Manufacturing (AM). Using subtractive processes, you must redesign the exterior of the part or select a lighter-weight material to reduce overall part weight. The top and bottom layers are printed solid (without infill), while the middle layers are printed with solid outer walls and the triangular infill pattern making up the interior structure.

The Anatomy of a Studio System™ Part

Infill

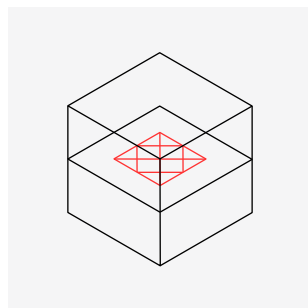

Shell

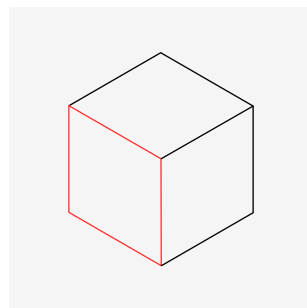

Walls

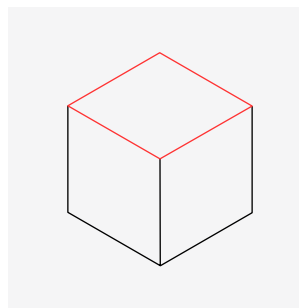

Top Layer

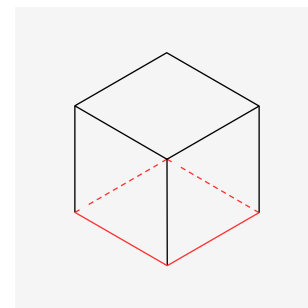

Bottom Layer

Considerations & Best Practices

Printing with Infill

Infill & Fabrication Time

The use of infill reduces the amount of material and time required to print a part. It also reduces the debind (v.1 materials) and sinter cycle times (v.2 materials) which depend on the cross-sectional thickness (wall thickness + lines of infill to the center of the part).

A solid part will take much longer to debind and sinter, or it might not fully debind which can lead to serious part defects like cracking or blistering.

Example Part Geometry

Printing with infill (lower left) reduces fabrication time, material cost, and part mass.

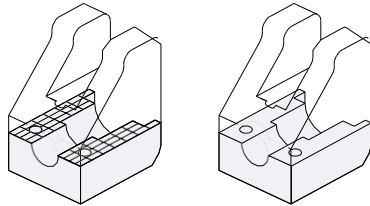
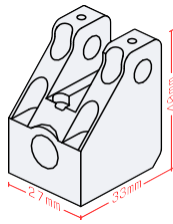

Example Part

Example Part
w/ Infill

Example Part
w/o Infill

Savings Due
to Infill

Print Time (Hours)

7

11

36%

Debind Time (Hours)

19

50

62%

Total Fabrication (Hours)

67

100

33%

Material (g)

170

280

40%

Cost of Material

\$20

\$33

40%

Final Part Mass (g)

118

220

46%

Infill & Part Strength

In combination with the outside shell, infill-based structures feature excellent rigidity at minimal weight. The shape of the infill geometry has a significant impact on both the effective modulus and the degree of anisotropy of structural properties.

For v.1 materials: The Studio System™ prints with triangular infill and TPMS infill structures, which offers several benefits over hexagonal or square infill geometries. Triangular infill results in a constant elastic modulus in the X-Y plane, ranging from 18-28% of the solid material's elastic modulus.

For v.2 materials: The TPMS infill structure has an isotropic geometry in the X Y Z directions, allowing for more even part properties than typical infill structures.

Considerations & Best Practices

Optimizing for Printing, Debinding, and Sintering

Cross-Sectional Thickness

The cross-sectional thickness is equal to the wall thickness plus the lines of infill to the center of the part in v.1 materials.

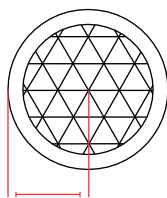

Strategies For Reducing Debind Time (for v.1 materials)

During the debinding process, the part is fully immersed in debind fluid. The debind fluid is a solvent that dissolves the wax portion of the binder to create an open-pore structure in the part allowing the remainder of the polymer binder to escape during sintering. The debind fluid surrounding the part must diffuse through the printed material until it reaches the center of the part. The distance that the fluid travels from the outer wall to the part center is known as the cross-sectional thickness. Live Studio uses the cross-sectional thickness to calculate debind time.

Debind time is impacted by the wall thickness of the part. The cross-section reveals the wall lines (the compound path created by the two perimeter circles) and the lines of triangular closed-cell infill. Debind fluid flows freely between the voids created by the infill, but dissolves slowly through the solid material of the wall lines and each line of infill. Increasing wall line count leads to an increase in the length of the debind cycle.

When using v.2 materials, a longer debinding step still occurs in the furnace. The length of this debinding step is impacted by the thickness of the shell of the part (walls, top layers, and bottom layers). With the TPMS structure of the v.2 materials, the amount of infill does not have a large impact on debind time, due to the large open channels of the TPMS structure.

Tip One

Reduce the cross-sectional thickness to shorten the debind time. For the example part, below, a cylindrical core has been removed.

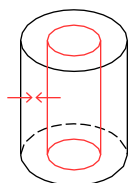
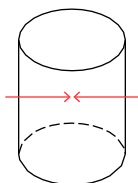

Tip 1 [using CAD]:

Reduce the cross-sectional thickness to shorten the debind time. Identify opportunities to modify your part design to reduce the cross-sectional thickness. One approach is to remove or 'core' thick sections of the part (similarly, you can add large indentations to thick sections of the part). For the example part, a cylindrical core has been removed. Now debind fluid can enter the part through the outer and inner walls. The distance to the center of the thick region of the part is, very noticeably, much smaller. This tip is most effective for solvent debind (v.1 materials).

» Coring Example: Mold Insert

Coring the mold insert reduced the debind time by 3.5X and 14X, depending on the design approach.

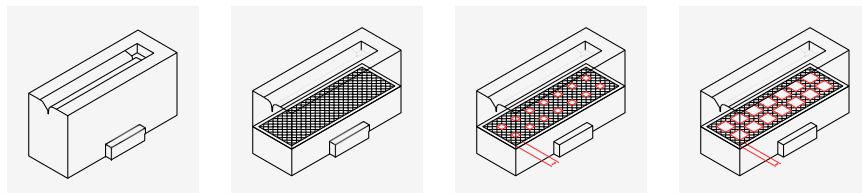

Tip 2 [using Live Studio]:

Live Studio's default setting for wall thickness, top layer, and bottom layer balance part strength and debind time. Increasing wall line count, top layer, and bottom layer in Live Studio's advanced settings can increase part strength, but will lead to longer debind times.

Considerations & Best Practices

Optimizing for Printing, Debinding, and Sintering

Optimize Print Orientation

The way you choose to orient your part during printing has implications for support material usage, surface quality, and fabrication time. Live Studio includes an auto orient algorithm, which automatically selects an orientation that minimizes support structures and lowers the center of gravity of the part. When orienting your part, consider the following:

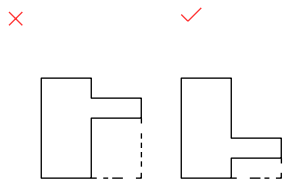

» Minimize support volume.

Minimize support volume to save print time and material. Avoid large overhanging portions of your part that rest on support structures.

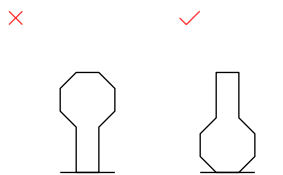

» Avoid high centers of gravity.

Avoid orientations that elevate the part's center of gravity.

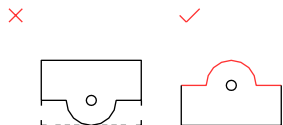

» Avoid critical surfaces in contact with supports.

Surfaces in contact with support structures will have rougher surface quality. It is best to avoid having critical surfaces contact support structures.



» Avoid wide cross sections areas over the layers on extended flat part, especially if shell thickness has been increased from default value. Wide flatness from blocky geometries is non optimal for binder to evaporate. Tilting the part by few degrees help so far by reducing cross section areas and evaporation pressure on a specific flat surface.

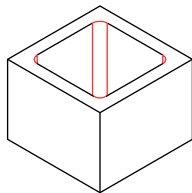

Fillet Sharp Inside Edges

Sharp edges can concentrate stress in the part and increase the risk of cracking during sintering. Whenever possible, add a fillet to sharp interior edges.

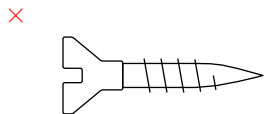

Avoid Printing Hardware

There are few instances when printing metal hardware will be less-expensive than purchasing it off-the-shelf. Be strategic and think about the cost and benefit of printing parts—hardware rarely makes sense to print.

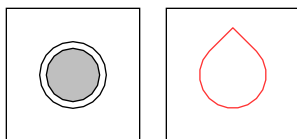

Holes

For horizontal holes of certain diameters supports may be necessary, but Live Studio automatically generates supports. Users can avoid using support structures for horizontal holes by redesigning the circular hole shape into a teardrop shape, which utilizes a self-supporting angle. The self-supporting angle eliminates the need for supports.

Considerations & Best Practices

Optimizing for Printing, Debinding, and Sintering

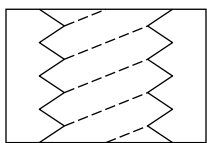

Printed Threads

Many 3D printing companies, including those selling laser powder-bed fusion systems, recommend printing holes and then tapping threads. For the Studio System, tapped threads are recommended for threads from M3 to M9. In these cases, increase the wall line count to 5-7 lines (3 lines is the default setting) to ensure adequate material for cutting threads. For threads M10 and larger, printing and chasing will produce the best results.

Thread Size	Method
< M10	Print hole, tap threads
≥ M10	Print threads, chase threads

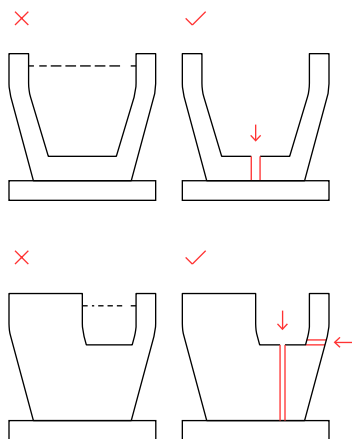

Cup-shaped Parts (Applicable for V1 materials only)

During the debinding process, the entire part is immersed in debind fluid. After debinding is complete, the fluid is drained from the tank and distilled for re-use in the next run. If the part being debound has a "cup" shape, that feature will hold debind fluid and prevent the part from completely drying.

Simple modifications can be made to parts to ensure that all of the debind fluid drains from the part being debound. Adding small drainage holes (as small as 1mm) to your part design will allow the fluid to drain.

Alternatively, part orientation can also be adjusted. Keep in mind that part should have the same orientation for printing, debinding, and sintering so changing the part orientation for debinding means changing the orientation for printing and sintering as well. It is recommended that users orient parts in a way that optimizes full process success.

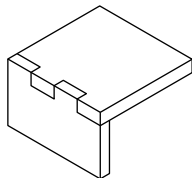
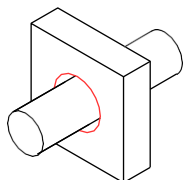

Clearances

» Printed-in-places assemblies

For components of a moving assembly, clearance of 0.3mm (0.012in) clearance is recommended between components.

» Close fit

For components to mate after sintering, a larger clearance of 0.3mm to 0.6mm (0.012-0.024in) is recommended.

Considerations & Best Practices

Optimizing for Printing, Debinding, and Sintering

Supports

The interface layer plays a very important role in the BMD part fabrication process. During the furnace cycle, the interface layer becomes a powder that physically keeps the part from sintering to the support structures. This is what enables Separable Supports™ and the significant benefit of allowing users to remove support structures by hand. However, for some geometries, the fact that support structures are not strongly attached to parts during the sintering process may mean that parts can shift or separate from supports during the sintering process.

One specific example is a feature that sits at an angle atop a support structure but does not meet the default angle requirement (of 40°) for generating overhang supports. In example one (shown below), the feature without overhang supports will slide down toward the base of the object during the sintering process. To prevent the part from shifting or sliding, the Live Studio angle setting for support overhang generation has been manually modified to a lower angle (below 40°), causing supports to build for the overhanging features. This support structure will now “cradle” the part during sintering, preventing the part from shifting.

Example One

Tip: Adjust the support angle to a lower angle, which will cause supports to build to the overhang features. The support structure will now “cradle” the part during sintering, preventing the part from shifting.

Modify support angle criteria to generate support for overhang.

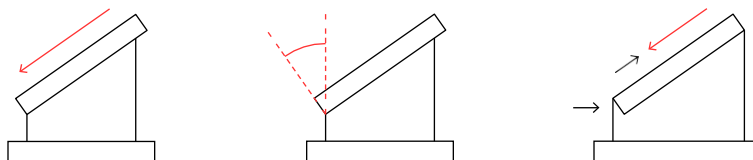

It is also possible for support structures to shift during the sintering process if they are built atop an angled surface. While a support structure with a flat base will remain stable during sintering process, one built on an angled base may want to slide away from the part. To avoid this situation, the original part geometry should be modified. Adding a small lip or bump to the part where it contacts the bottom of the support structure will prevent the support structure from shifting during sintering.

Modify part geometry to secure support structure.

Example Two

Tip: If you notice that Live Studio is generating supports with an angled base, consider modifying your design in CAD. Add a small lip or bump to the part where it contacts the bottom of the support structure.

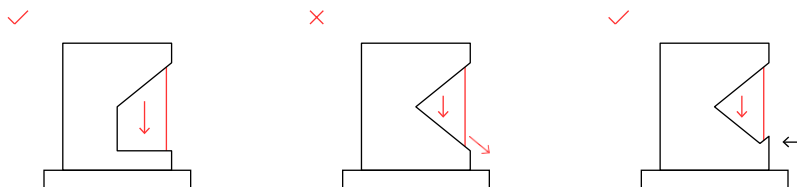

Considerations & Best Practices

Optimizing for Printing, Debinding, and Sintering

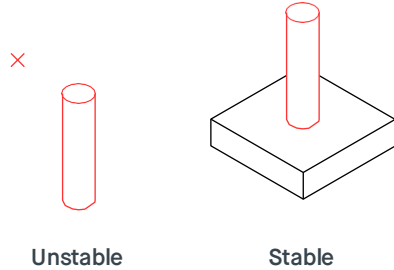

Aspect Ratio

The most slender vertical cylinder that can be printed, debound, and sintered has an aspect ratio of 8:1 (height : diameter – copper is 6:1) and is attached to a larger base – rather than being a free-standing feature. If the slender cylinder is a free-standing feature and sits directly on the raft instead of being attached to a part, the cylinder will be less stable. This is because the cylinder will sit directly on the ceramic interface layer, which turns to a powder during the sintering process, creating an unstable base for the cylinder to sit on. For free-standing cylinders, the aspect ratio of the feature should be reduced by 40% to about 5:1.

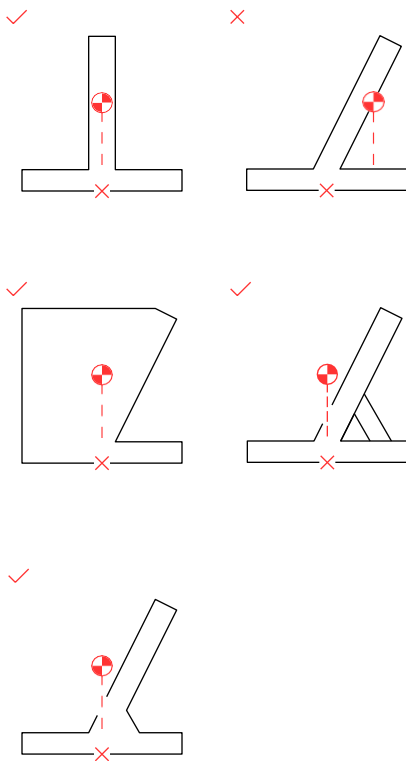

Most features and parts are not perfect vertical cylinders. In these cases, it is important to note where the center of gravity of the feature is located. Features are most stable when the center of mass is sitting above the base of the feature. A less stable feature is one where the center of mass is not vertically supported. An example is a tall pillar on a slight angle (shown left). During sintering, when the material is weak, the feature will want to fall over, or slump.

There are a few options for addressing features whose center of mass does not sit above the base of the features. Through modifications to the original geometry, stable features can be created. The first solution is to attach the overhanging feature to a larger, more stable part. In this instance, the center of mass has now been moved to a location above the base of the feature. Another solution is to add support trussing, pillars, or other features. When adding supporting features, attach them to the original feature in a manner that will support the part during sintering. It is good practice to ensure that the center of mass is located within the bounds of the base of the original feature and support features.

Glossary

Studio System Printer

Desktop Metal's office-friendly metal 3D printer.

Studio System Debinder

Desktop Metal's office-friendly debinder; immerses the part to remove binding material, creating an open-pore structure in preparation for sintering.

Studio System or Desktop Metal Furnace

Desktop Metal's office-friendly sintering furnace; sinters the part to remove remaining binder and produce a metal part with densities between 96-99.8% (depending on the material).

Live Studio™

With expert metallurgy built-in, Live Studio software controls your Studio System workflow from digital model to sintered part.

Separable Supports™

Technology in which parts are easily separated from their support structures due to a Ceramic Release Layer (or interface layer).

Studio System Materials

Metal or ceramic materials available for the Studio system; specially-formulated bound metal or ceramic rods.

17-4 PH Media Cartridge

Metal particles mixed in a plastic binder. This is the material that is printed and forms the final metal part.

Interface Media

Ceramic particles mixed in a plastic binder. Used to keep support structures from sintering to the part in the furnace.

Green Part

The state of the part after printing, before debinding.

Brown Part

The state of the part after debinding, before sintering.

Sintered Part

The state of the part after sintering.

Print Sheet

A polypropylene sheet that the part is printed on top of. The sheet is removed from the build platform after printing has finished, and the part is peeled from the sheet. Sheets are designed to be single use.

Debind Fluid

Solvent that is used to debind Studio System parts - see the SDS for more information.

Gas no. 1 / Gas no. 2

Gas that is used in the furnace during the sintering cycle. Ensures an inert environment during sintering. Gas no.1 is a 3%H₂/Ar blend, while gas no.2 is pure Ar.